

# DATA SHEET

## Hall Effect Voltage Sensor



PN: CHV\_AV15D5

IPN=200~1000V

### Feature

- Closed- loop (compensated) voltage transducer
- Capable measurement of DC and AC voltage with galvanic isolation between primary circuit and secondary circuit.
- Supply voltage: DC  $\pm 12 \sim 15$  V

### Advantages

- High accuracy
- Easy installation
- Low temperature drift
- High immunity to external interference

### Applications

- The application of induction cooker
- AC/DC variable-speed drive
- Uninterruptible Power Supplies (UPS)
- Switched Mode Power Supplies (SMPS)
- Inverter applications



RoHS



### Electrical data: ( $T_a=25^\circ\text{C}$ , $V_c= \pm 15\text{VDC}$ )

Parmeter \ Ref	CHV200 AV15D5	CHV400 AV15D5	CHV600 AV15D5	CHV800 AV15D5	CHV1000 AV15D5
Rated input voltage $V_{pn}(V)$	200	400	600	800	1000
Measuring range $V_p(V)$	$0 \sim \pm 280$	$0 \sim \pm 360$	$0 \sim \pm 840$	$0 \sim \pm 1120$	$0 \sim \pm 1400$
Turns ratio $N_p/N_S (T)$	1000	1000	1000	1000	1000
Secondary coil resistance $R_S (\Omega)$	60	60	60	60	60
Output voltage $V_O(V)$	$\pm 5.0 * V_P / V_{PN}$				
Supply voltage $V_C(V)$	$(\pm 12 \sim \pm 15) \pm 5\%$				
Accuracy $X_G(\%)$	@IPN, $T=25^\circ\text{C}$		< $\pm 0.5$		
Offset voltage $V_{OE}(mV)$	@IP=0, $T=25^\circ\text{C}$		< $\pm 40$		
Temperature variation of VOE $V_{OT}(mV/^\circ\text{C})$	@IP=0, $-40 \sim +85^\circ\text{C}$		< $\pm 0.5$		
Linearity error $\epsilon_r(\%FS)$	< 0.2				
Response time $t_{ra}(\mu s)$	@90% of IPN		< 40.0		
Power consumption $I_C(mA)$	15+ $I_s$				

Insulation voltage Vd(KV)	@50/60Hz, 1min,AC	2.5
---------------------------	-------------------	-----

### General data:

Parameter	Value
Operating temperature TA(°C)	-40 ~ +85
Storage temperature TS(°C)	-55~ +125
Mass M(g)	50
Plastic material	PBT G30/G15, UL94- V0;
Standards	IEC60950-1:2001
	EN50178:1998
	SJ20790-2000

### Dimensions(mm):

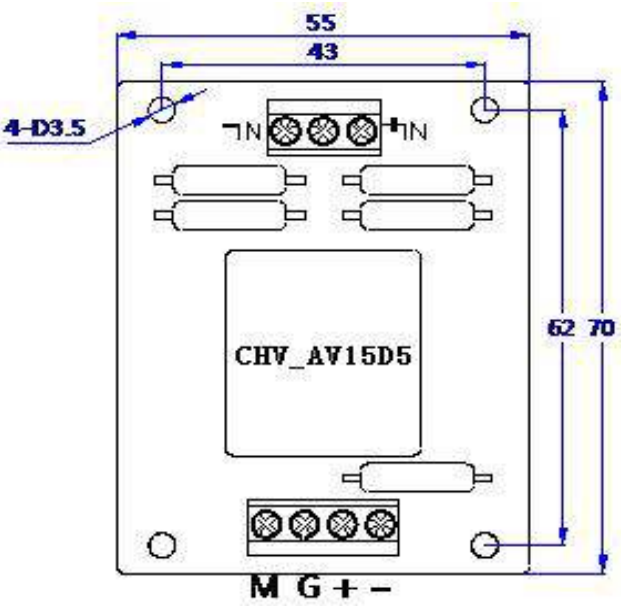
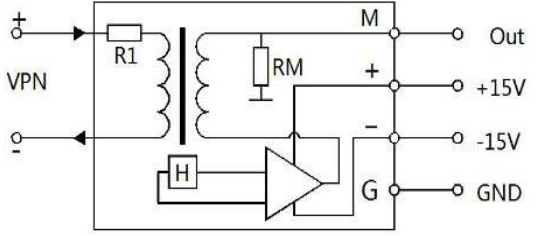
	<p>Connection</p> 
	<p>General tolerance</p>
	<p>General tolerance: &lt;math&gt;\pm 0.5\text{mm}&lt;/math&gt;  size of Primary pin:  DG301-5.0-03P;  Secondary pin: DG301-5.0-04P</p>

### Remarks:

- When the current goes through the primary pin of a sensor, the voltage will be measured at the output end.
- Custom design is available for the different rated input current and the output voltage.

**WARNING : Incorrect wiring may cause damage to the sensor.**