

DATA SHEET

Hall Effect Current Sensor



PN:CHK-HAHE5S2L

IPN=50-1500A

Feature

- Open- loop
- Capable measurement of currents: DC, AC,pulse with galvanic isolation between primary circuit and secondary circuit.
- Internal circuit adopts ASIC packaging technology products
- Supply voltage: DC +5.0V

Advantages

- Good accuracy for high and low current range
- Good linearity
- Low thermal offset drift
- Low thermal sensitivity drift

Applications

- EV and utility vehicle
- Battery pack monitoring
- Hybird Vehicles
- Uninterruptible Power Supplies (UPS)
- Inverter applications



RoHS



Electrical data: (Ta=25°C, Vc=+5.0VDC,RL=10KΩ)

Parmeter Ref	CHK50 HAHE 5S2L	CHK10 0HAHE 5S2L	CHK20 0HAHE 5S2L	CHK40 0HAHE 5S2L	CHK60 0HAHE 5S2L	CHK80 0HAHE 5S2L	CHK10 00HAH E5S2L	CHK12 00HAH E5S2L	CHK15 00HAH E5S2L
Rated input Ipn(A)	50	100	200	400	600	800	1000	1200	1500
Measuring range Ip(A)	0 ~ ±56	0 ~ ±112	0 ~ ±225	0 ~ ±450	0 ~ ±675	0 ~ ±900	0 ~ ±1000	0 ~ ±1200	0 ~ ±1500
Sensitivity S(mV/A)	40	20	10	5	3.33	2.5	2	1.67	1.33
Output voltage Vo(V)	$V_c/2 \pm I_p * S$								
Output voltage Vo(V)	@Ip=0,T=25°C ,+5V				$V_c/2$				
Supply voltage Vc(V)	+5.0 ±5%								
Current consumption	<20								

Ic(mA)		
Offset voltage V _{OE} (mV)	@I _p =0, T=25°C	< ±5.0
Hysteresis offset voltage V _{OH} (mV)	@IP=0, after 1*IPN	< ±3.0
Temperature variation of V _{OE} V _{OT} (mV/°C)	@IP=0, -40 ~ +85° C	< ±0.5
sensitive error XG(%)	@T=25° C	±0.5
	@-40° C < T < 125° C	< ±1.5
Linearity error ε _r (%FS)		< ±0.5
Load resistance R _L (KΩ)		> 10
Capacitive loading CL(nF)		1~10
Output clamping voltage min V _{SZ} (V)	@V _C =5.0V	0.24~0.26
Output clamping voltage max V _{SZ} (V)	@V _C =5.0V	4.74~4.76
Output internal resistance R _{out} (Ω)		1~10
Bandwidth BW(KHZ)	@-3DB	30
Response time Tra(μs)	@90% of IPN ,	< 7.0

Absolute maximum ratings:

Parameter	Value	Conditions
Supply voltage V _C (V)	<6.0	
	6.0	@1min, T=25° C
	-0.1	@1min, T=25° C

General data:

Parameter	Value
Operating temperature T _A (°C)	-40 ~ +125
Storage temperature T _S (°C)	-55 ~ +125
Mass M(g)	65
Plastic material	PBT G30/G15, UL94- V0;
Standards	IEC60950-1:2001
	EN50178:1998
	SJ20790-2000

Dimensions(mm):

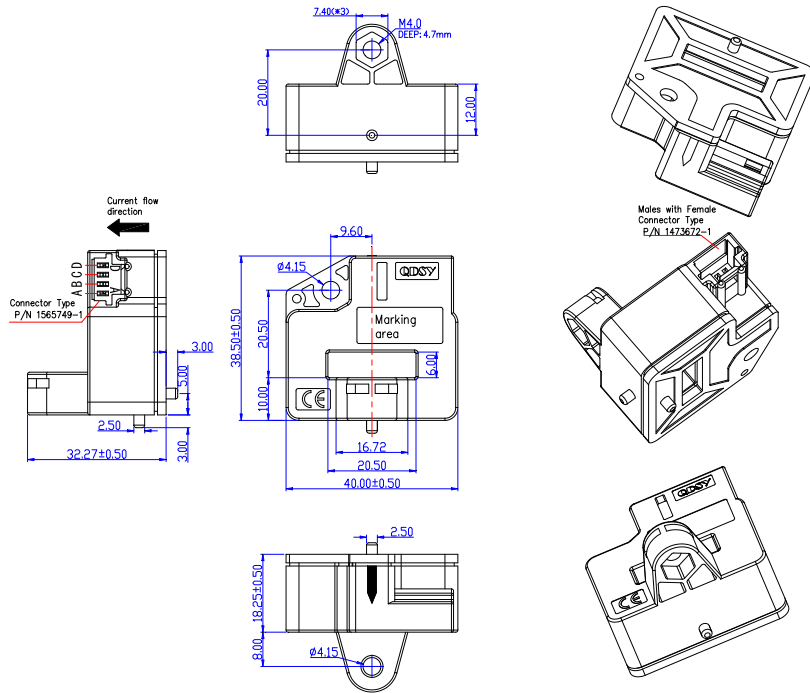

Connection

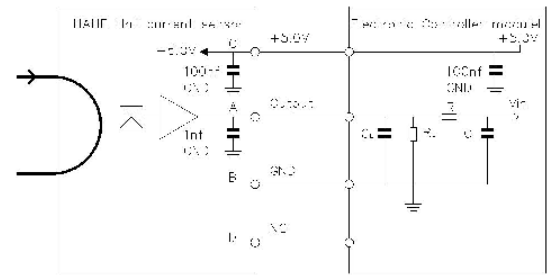

Bill of Materials

Plastic case :PBT GF30

Magnetic core: Iron silicon alloy

Electrical terminal:Brass tin plated

Connector type: TYCO 1473672-1

General tolerance

General tolerance:< ±0.5mm

Primary through-hole: 20.5*6.0±0.5

Remarks:

- When the current goes through the primary pin of a sensor, the voltage will be measured at the output end.
- Custom design is available for the different rated input current and the output voltage.
- The dynamic performance is the best when the primary hole is fully filled with.
- The primary conductor should be <100°C.

WARNING : Incorrect wiring may cause damage to the sensor.