

# DATA SHEET

## Hall Effect Current Sensor



**PN: CHB\_LTHA15D**

**IPN=100~300A**

### Feature

- Closed- loop (compensated) current transducer
- Capable measurement of currents: DC, AC,pulse with galvanic isolation between primary circuit and secondary circuit.
- Supply voltage: DC  $\pm 12\sim 18V$

### Advantages

- High accuracy
- Easy installation
- Low temperature drift
- Optimized response time
- High immunity to external interference

### Applications

- Variable speed drives
- Welding machine
- Battery supplied applications
- Uninterruptible Power Supplies (UPS)
- Electrochemical



RoHS



### Electrical data $T_a=25^{\circ}C$ $V_c= \pm 15VDC$

Parmeter	Ref	CHB100LTHA1	CHB200LTHA1	CHB300LTHA1	CHB300LTHA1
		CHB100LTHA2	CHB200LTHA2	CHB300LTHA2	CHB300LTHA2
Rated input $I_{pn}(A)$		100	200	300	300
Measuring range $I_p(A)$		300 ( $\pm 18V$ , 80 $\Omega$ )	600 ( $\pm 18V$ , 20 $\Omega$ )	750 ( $\pm 18V$ , 10 $\Omega$ )	900 ( $\pm 18V$ , 3.0 $\Omega$ )
Turns ratio $N_p/N_S (T)$		1:2000	1:2000	1:2000	1:3000
Output current rms $I_S(mA)$		50 $\pm 0.2\%$	100 $\pm 0.2\%$	150 $\pm 0.2\%$	100 $\pm 0.2\%$
Secondary coil resistance $R_S (\Omega)$		25	35	30	52
Measure resister with $\pm 12V$ RM ( $\Omega$ )		@100Amax 190(max)	@200Amax 68(max)	@300Amax 39(max)	@300Amax 56(max)
		@200Amax 80(max)	@500Amax 7.5(max)	@500Amax 12(max)	@600Amax 2.0(max)
Measure resister with $\pm 15V$ RM ( $\Omega$ )		@100Amax 250(max)	@200Amax 100(max)	@300Amax 62(max)	@300Amax 91(max)
		@200Amax 110(max)	@500Amax 20(max)	@700Amax 10(max)	@750Amax 2.0(max)
Supply voltage $V_C(V)$		$\pm 12\sim \pm 18$			

Offset current drift(mA)	@ -40°C ~ 85°C	≤±0.5
Accuracy XG(%)	@IPN,T=25°C	< ±0.1
Linearity error $\epsilon_r$ (%FS)	@ $I_p=0-\pm I_{pn}$	≤0.1
Di/dt accurately followed A/μs		> 100
Response time $\tau_{ra}$ (μs)	@100A/μS, 10%-90%	<1.0
Power consumption $I_C$ (mA)		≤20+ $I_p X(N_p/N_s)$
Bandwidth BW(KHZ)	@ -3db	DC...150
Insulation voltage $V_d$ (KV)	@ 50HZ,AC,1min	6

## General data

Parameter	Value
Operating temperature $T_A$ (°C)	-40 ~ +85
Storage temperature $T_S$ (°C)	-40 ~ +125
Mass $M$ (g)	79
Plastic material	UL94-V0.
Standards	EN60947-1:2004
	IEC60950-1:2001
	EN50178:1998
	SJ 20790-2000

## Dimensions(mm):

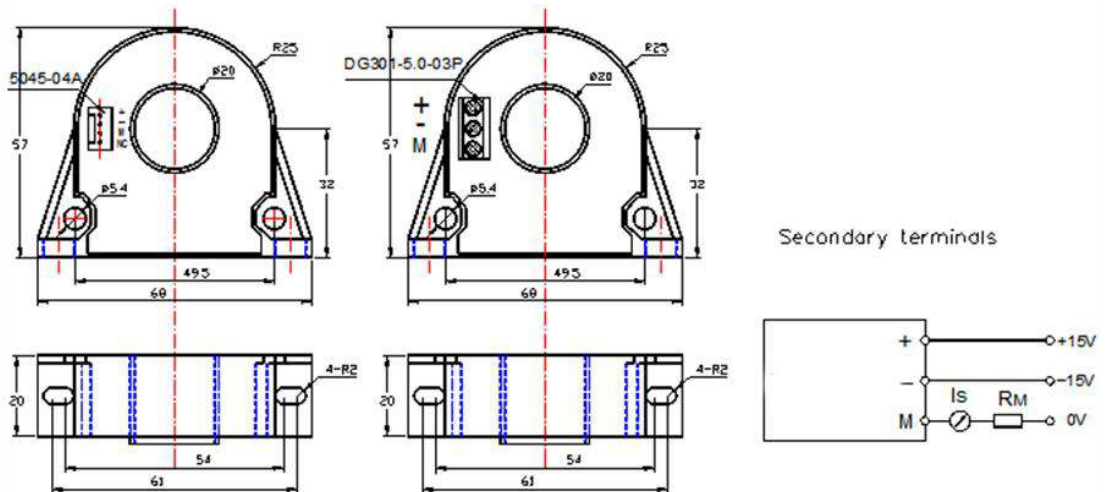

## Remarks

1. All dimensions are in mm.
2. General tolerance ±1mm.

## Characteristics chart:

Pulse current signal response characteristic

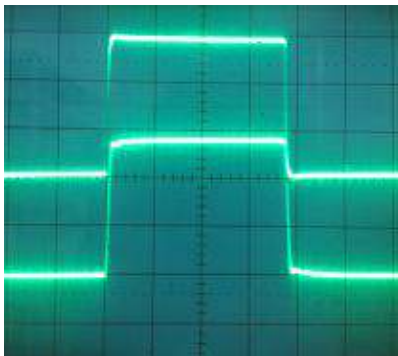

← input signal

← output signal

Effects of impulse noise

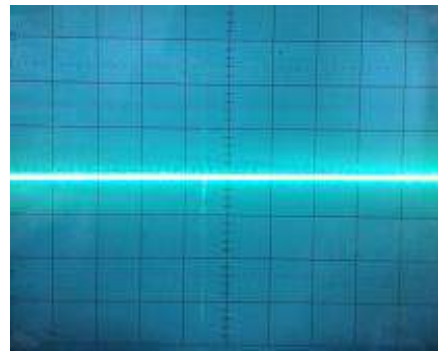

← Output voltage

## Directions for use

- When the current goes through the primary pin of a sensor, the voltage will be measured at the output end.
- $I_s$  will be in a forward direction when the  $I_p$  flows according to the direction of arrowhead.
- Custom design is available for the different rated input current and the output voltage.
- The dynamic performance is the best when the primary hole is fully filled with.
- The primary conductor should be  $\leq 100^\circ\text{C}$ .

**WARNING : Incorrect wiring may cause damage to the sensor.**